

THE PAINT STUDIO 

DREAM IN COLOR

DÉCOR CATALOG

PAINT REINVENTION DÉCOR CATALOG



PRODUCT CATALOG

TABLE OF CONTENTS

TODAY



REINVENTED



LET'S GET STARTED!

PRODUCT CATALOG

TABLE OF CONTENTS

SUMMARY OF KEY TERMS 5

COLOR CENTERS 6

RETROFIT KITS 13

DEPARTMENT DÉCOR 24

SUMMARY OF KEY TERMS AND CONDITIONS

ACE + VALSPAR FULL PROGRAM PARTICIPATION

1. **100% credit – for the following components including unit cost, install and applicable other expenses**

- Color Centers: Ace recommended configuration of 8' Chip Racks (or in limited cases 4' Chip Rack) for Ace and Valspar AND 3' End Caps for Ace and Valspar
 - Any 4' chip rack recommendation is eligible for an upgrade to an 8' chip rack for a full credit
 - Retailer is not eligible to downgrade from an 8' to a 4' chip rack
- Department Overhead Sign
- Ace recommended Tinter configuration
- Reset labor – up to twenty 4' section merchandise moves WITHIN PAINT DEPARTMENT. Retailer WILL BE RESPONSIBLE for the cost of any merchandise moves above this limit
- Installation for the listed components, freight, delivery to Retailer door, shipping, handling and taxes for these components.

2. **Funded Décor – “Your Choice Of One Free Item”:**

- (1) Paint Counter Retrofit for one complete counter which may include front counter and backdoors.
 - Alternatively, Retailer may elect to apply a credit of \$800 for New Stainless Desk.
- (2) : one Center Hospitality End-Cap OR one Set of Category Markers with or without Soft Pillar (set of 6 markers)
 - Center Hospitality End-Cap offer includes either (1) a new FREESTANDING fixture OR (2) a DRESS-UP kit for the existing 3' End Cap (Dress-Up Kit requires an existing fixture)
 - Freestanding Center Hospitality End-Cap does NOT include any additional hospitality area components.

3. **Window/Exterior Signs**

- Any window sign upgrade will receive a \$200 credit. Includes window face replacements, interior or exterior signs.
- Alternatively - orders placed outside of this ordering process, including orders placed with Retailer's local vendors, may be eligible for coop funds. Note: the mechanics of the coop credit process are in development. Please request further details at ReinventDecorOrders@acehardware.com

4. **Other Optional and Mandatory Components – for Purchase**

- Décor, tinting equipment and peripherals – upgrades available with cost difference funded by Retailer
- Color matching software and equipment – all upgrades funded by Retailer. Ace/Valspar Formula Book upgrade FUNDED BY ACE.
- Reset labor and fixturing – any cost above twenty 4' section merchandise moves or additional fixturing work outside of Ace funded components

5. **Credit Terms: Any net balance due from Retailer is eligible for 180-days datings terms, subject to a minimum balance due of \$1,000.**

6. **Any Retailer NOT participating in the Valspar Program will represent an exception and must be routed to ReinventDecorOrders@acehardware.com for approval; If approved - Only 50% credit will be eligible.**

COLOR CENTERS

PAINT REINVENTION

For any questions regarding your Order or items in this Catalog work with your DM or e-mail
ReinventDecorOrders@acehardware.com

CLARK+KENSINGTON 8' CHIP RACK

COLOR CENTERS



1. Color quadrants make finding the right color easier. This new display divides 1,136 colors into warm and cool, muted and bright, minimizing anxiety about finding the right color.
2. Center graphic is designed to grab attention and is also updatable to keep the system looking current.
3. Pivoting sheen bar showcases finishes at eye-level, close to the light source so consumers can quickly understand differences and make a selection.
4. Display base provides convenient color collateral storage space for quick and easy replenishment.

Page #1 of Order Form
Clark+Kensington 8' Color Center
Part #40
Offer: **FREE**
Available: Now
Specifications: 95.5"L x 23.75"D x 95.75"H

CLARK+KENSINGTON 4' CHIP RACK

COLOR CENTERS



1. Displays Most Colors - Holding most of the colors of the 8' Clark+Kensington display, this 4' fixtures is compact but powerful.
2. Color Collateral - It has all of the same color collateral as the 8' display and houses the extra colors, that were removed from the main display, in a compact color caddy held in the base cabinet.
3. Sheen bar showcases finishes at eye-level, close to the light source so consumers can quickly understand differences and make a selection.
4. Color Caddy - This caddy can be easily removed for consumers to view at the counter.

**AVAILABLE
TO SHIP IN
NOVEMBER 2013**

Page #1 of Order Form
Clark+Kensington 4' Color Center
Part #50
Offer: **FREE**
Available: 11/1
Specifications: 47.875" L x 23.75" D x 95.75"H

CLARK+KENSINGTON 3' ENDCAP

COLOR CENTERS



1. Mix + Match + Play Palette includes 120 gorgeous colors that work together to make selection easy. Inspirational panoramic room scenes paired with large color swatches are perfect for consumers who are ready for color but don't want to be overwhelmed.
2. Updatable Backlit Graphic draws consumers in with fresh messaging using bright and long-lasting LED lighting. The backlit graphic can be swapped out for a media player (see 5).
3. Do-It-In-A-Day Project Magazine inspires consumers to purchase and use paint in non-traditional ways with quick and easy weekend projects.
4. Clark+Kensington Palette Card includes all 120 "Simple.Smart.Beautiful" colors in a portable take-home piece, that they can keep as a ready reference for future paint projects.
5. Media Player (option) displays inspirational photography in an engaging rotational rotational video that sparks imaginations and gets consumers excited to transform their space.

Page #1 of Order Form
Clark+Kensington 3' Endcap
Part #60
Offer: **FREE**
Available: Now
Specifications:
47.17"L x 20.9"D x 112.25"H

Page #4 of Order Form
Monitor (Media Player)
Part #70
Offer: Optional for Purchase
Available: Now
Specifications: 15"L x 2"D x 9⁵/₈"H

VALSPAR 8' CHIP RACK

COLOR CENTERS



1. Rainbow Inspired Palette with flowing blocks of bright, muted and neutral shades arranged in recognizable color families, draws in Color Confident consumers who love exploring. Expertly-chosen selection of 580 shades focused on tried-and-true colors, minimizing color redundancy in rack and reducing confusion for consumers as they narrow choices.
2. Generously sized 3" x 3.5" Single-Color Chips give consumers a large, easy-to-visualize color swatch.
3. Innovative Boutique Color Drawers each featuring 24 mood-themed, coordinated colors attract Color Anxious consumers who feel more comfortable with smaller, focused options. Mood themes help them find colors quickly: Cozy, Carefree, Serene and Luxe. Drawers auto-retract to maximize traffic flow.
4. Display base provides convenient storage for color collateral.

Page #1 of Order Form
Valspar 8' Color Center
Part #10
Offer: **FREE**
Available: Now
Specifications: 95.5"L x 23.75"D x 95.75"H

VALSPAR 4' CHIP RACK

COLOR CENTERS



1. The 4' Color Display features a dynamic subset of colors found in the Valspar 8' display.
2. Consumer can still see a large “reveal” of color in the display and have a sizeable selection to choose from.
3. Features two boutique drawers and key color brochures displayed in the center panel in direct line-of-sight
4. Display base provides convenient storage for color collateral.

**AVAILABLE
TO SHIP IN
NOVEMBER 2013**

Page #1 of Order Form
Valspar 4' Color Center
Part #20 4'
Offer: **FREE**
Available: 11/1
Specifications: 47.875"L x 23.75"D x 95.75"H

VALSPAR 3' ENDCAP

COLOR CENTERS



1. Valspar Color Guarantee backlit panel draws in consumers with a bold splash of color and promise that inspires a confident color purchase. (See back of brochure for complete details).
2. Timeless Trios Color Boutique features three contemporary, style-inspired themes and colorful photography that draws in Color Anxious shoppers seeking quick and easy color solutions. Includes 54 additional colors curated into expertly coordinated, easy-to-shop color trios.
3. Color Trio Idea Cards inspire both Color Confident and Color Anxious consumers with eye-catching imagery on front and three stylish room settings with coordinated color trios inside. Featured in rack, drawers and endcap.
4. Rotating sheen guide integrated into display for easy access and sheen comparison

Page #1 of Order Form
Valspar 3' Endcap
Part #30
Offer: FREE
Available: Now
Specifications: 47.17"L x 20.9"D x 112.25"H

PAINT COUNTER RETROFIT KITS

PAINT REINVENTION

1. Details on the following pages of this Catalog are provided for FRONT COUNTER RETROFIT KITS only. Counter Retrofit Kits do NOT include Backdoors. If Backdoors Kits are required - you may pick from available options and order these on the Order Form.

2. Offer: full credit for one Counter Retrofit Kit

- Alternative: \$800 credit for new stainless desk Front Counter - Stainless Counters (4' + 3') with Brand Glorifier Shelf and Tintable Pint Sample Messaging Display (Order Part #80). Note: New Counter does NOT include a rear counter. If you choose the \$800 credit offer toward the cost of a new desk, you are eligible for one retrofit kit for the backdoors for the rear counter. Please refer to the Retrofit Kits section of the Order Form for further details.

For any questions regarding your Order or items in this Catalog work with your DM or e-mail
ReinventDecorOrders@acehardware.com

RETROFIT KITS*

FRONT COUNTER

Because the original Paint Counters are still highly functional, this Retrofit Kit gives the original counters a facelift. The laminate overlays coordinate with the new design aesthetic of the store paint department décor. It also features a modular can glorifier to quickly reference key product attributes among paint lines.



Retrofit Kits will include:

- 1. Plastic cover-up panels to skin existing desk**
- 2. Glorifier Wall with shelf to merchandise new paint lines.
(Glorifier Wall cannot be added to desks 3' and smaller)**
- 3. Mounting brackets, metal corner trim pieces, and all necessary hardware**

Your DM and Reset Group will help make a decision!

Key questions to consider:

1. Which make is your front counter:

Retail First (3 kits) – curved front: most common make among Ace Retailers

Lozier (5 kits) – flat front: less common among Ace Retailers

2. How long is your desk?

3. Do you need a kit for the extension counter / wing?

4. Do you need a kit for the backdoors?

Page #2 of Order Form

Paint Counter Retrofit Kits

Parts #100-171

Offer: "Your Choice Of" one complete kit

Alternative Offer: \$800 Credit toward New Front Counter

Order Part #80

Available: Now

Specifications: see following pages

RETROFIT KITS

FRONT COUNTER

The desks that are currently in-store primarily fall into two categories – They are either manufactured by Retail First (most common among Ace Retailers) or Lozier (less common among Ace Retailers). Some stores that have custom desks.

RETAIL FIRST

Kits for Retail First Counters

Kit #1

#53 – Paint Counter – 96”L x 30”D x 42”H

#58 – Paint Counter – 72”L x 30”D x 42”H

#57 – Paint Counter – 48”L x 30”D x 42”H

Kit #2

#61 – Paint Counter – 36”L x 30”D x 42”H

Add-on kit for the Retail First desk are:

Kit #3

#54 – Left Counter Extension – 24”L x 24”D x 36”H

#55 – Right Counter Extension – 24”L x 24”D x 36”H

LOZIER

Kits for Lozier Counters

Kit #4

WCC6331 – Paint Counter – 96”L x 30”D x 42”H

WCC6351 – Paint Counter – 48”L x 30”D x 42”H

Kit #5

WCC6332 – Paint Counter – 96”L x 30”D x 33”H

Kit #6

WCC6333 – Paint Counter – 96”L x 30”D x 36”H

WCC6361 – Paint Counter – 54”L x 24”D x 36”H

WCC6362 – Paint Counter – 48”L x 24”D x 36”H

Add-on kits for the Lozier desk are:

Kit #7

WCC6363 – Paint Counter – 36”L x 24”D x 36”H

Kit #8

WCC6342 – Side Counter – 24”L x 30”D x 33”H

KIT #1

RETROFIT KITS



FRONT
VIEW

Kit #1 RETAIL FIRST - FRONT COUNTER

#53 - Paint Counter - 96"L x 30"D x 42"H

#58 - Paint Counter - 72"L x 30"D x 42"H

#57 - Paint Counter - 48"L x 30"D x 42"H

Desk has curved front

Kit contains:

- (4) plastic cover up panels 29"W x 35"H with double face adhesive tape applied.
- (2) 35" tall metal corner trim with screws
- (1) tall glorifier wall
- (1) set mounting brackets for Retail First counter with mounting hardware



BACK
VIEW

Page #2 of Order Form
Retail First Paint Counter Retrofit Kits
Parts #100-171
Offer: "Your Choice Of" one complete kit
Alternative Offer: \$800 Credit toward New
Counter (Part #80)
Available: Now

KIT #2

RETROFIT KITS



FRONT
VIEW

Kit #2 RETAIL FIRST - FRONT COUNTER

#61 - Paint Counter - 36"L x 30"D x 42"H

Desk has curved front

Kit contains:

- (1) plastic cover up panel 36"W x 35"H with double face adhesive tape applied
- (2) plastic cover up panels 29"W x 35"H with double face adhesive tape applied
- (2) 35" tall metal corner trim with screws



BACK
VIEW

Page #2 of Order Form
Retail First Paint Counter Retrofit Kits
Parts #100-171
Offer: "Your Choice Of" one complete kit
Alternative Offer: \$800 Credit toward
New Counter (Part #80)
Available: Now

KIT #3

RETROFIT KITS

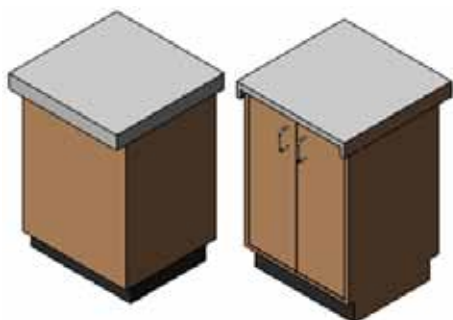

Kit #3 RETAIL FIRST - COUNTER EXTENSION

#54 - Left Counter Extension - 24"L x 24"D x 36"H

#55 - Right Counter Extension - 24"L x 24"D x 36"H

Extension has a flat-front, main paint desk is curved

Kit contains:

- (2) plastic cover up panels 23"W x 29"H with double face adhesive tape applied
- (1) 29" tall metal corner trim with screws

LEFT
COUNTER
EXTENSION



RIGHT
COUNTER
EXTENSION

Page #2 of Order Form
Retail First Paint Counter Retrofit Kits
Parts 100-171
Offer: "Your Choice Of" one complete kit
Alternative Offer: \$800 Credit toward New
Counter (Part #80)
Available: Now

KIT #4

RETROFIT KITS



FRONT
VIEW

Kit #4 LOZIER - FRONT COUNTER

#WCC6331 - Paint Counter - 96"L x 30"D x 42"H

#WCC6351 - Paint Counter - 48"L x 30"D x 42"H

Desk has flat front

Kit contains:

- (4) plastic cover up panels 29"W x 36.560"H with double face adhesive tape applied
- (2) 36.560" tall metal corner trim with screws
- (1) Tall Glorifier Wall
- (1) set Mounting brackets for Lozier counter with mounting hardware



BACK
VIEW

Page #2 of Order Form
Lozier Paint Counter Retrofit Kits
Parts #100-171
Offer: "Your Choice Of" one complete kit
Alternative Offer: \$800 Credit toward New
Counter (Part #80)
Available: Now

KIT #5

RETROFIT KITS



FRONT
VIEW

Kit #5 LOZIER - FRONT COUNTER

#WCC6332 - Paint Counter - 96"L x 30"D x 33"H

Desk has flat front

Kit contains:

- (4) plastic cover up panels 29W x 27.718H with double face adhesive tape applied
- (2) 27.718" tall metal corner trim with screws
- (1) short glorifier wall
- (1) set mounting brackets for Lozier counter with mounting hardware



BACK
VIEW

Page #2 of Order Form
Lozier Paint Counter Retrofit Kits
Parts #100-171
Offer: "Your Choice Of" one complete kit
Alternative Offer: \$800 Credit toward New
Counter (Part #80)
Available: Now

KIT #6

RETROFIT KITS



FRONT
VIEW

Kit #6 LOZIER - FRONT COUNTER

#WCC6333 - Paint Counter - 96"L x 30"D x 36"H

#WCC6361 - Paint Counter - 54"L x 24"D x 36"H

#WCC6362 - Paint Counter - 48"L x 24"D x 36"H

Desk has flat front

Kit contains:

- (4) plastic cover up panels 29W x 30.25" with double face adhesive tape applied
- (2) 30.25" tall metal corner trim with screws
- (1) short glorifier wall
- (1) set mounting brackets for Lozier counter with mounting hardware



BACK
VIEW

Page #2 of Order Form
Paint Counter Retrofit Kit
Parts #100-171
Offer: "Your Choice Of" one complete kit
Alternative Offer: \$800 Credit toward New
Counter (Part #80)
Available: Now

KIT #7

RETROFIT KITS

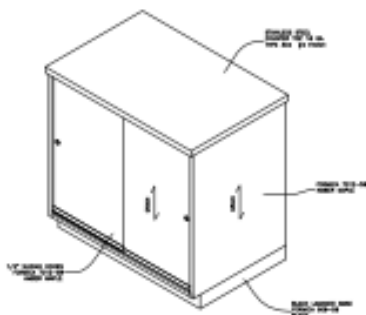

Extension counter has sliding doors

Kit #7 LOZIER - EXTENSION COUNTER

#WCC6363 - Paint Counter - 36"L x 24"D x 36"H

Desk has flat front

Kit contains:

- (1) plastic cover up panels 36"W x 30.250" with double face adhesive tape applied
- (2) plastic cover up panels 29"W x 30.250" with double face adhesive tape applied
- (2) 30.250" tall metal corner trim with screws



LEFT
COUNTER
EXTENSION

RIGHT
COUNTER
EXTENSION

Page #2 of Order Form
Paint Counter Retrofit Kit
Parts #100-171
Offer: "Your Choice Of" one complete kit
Alternative Offer: \$800 Credit toward New Counter
(Part #80)
Available: Now

KIT #8

RETROFIT KITS



Extension counter has shelves and no doors

Kit #8 LOZIER - EXTENSION COUNTER

#WCC6342 - Paint Counter - 24"L x 30"D x 33"H

Desk has flat front

Desk does not have doors on the back, just shelves

Kit contains:

- (2) plastic cover up panels 29W x 27.718H with double face adhesive tape applied
- (2) 27.718" tall metal corner trim with screws

LEFT
COUNTER
EXTENSION



RIGHT
COUNTER
EXTENSION

Page #2 of Order Form
Retail First Paint Counter Retrofit Kits
Parts 100-171
Offer: "Your Choice Of" one complete kit
Alternative Offer: \$800 Credit toward New Counter
(Part #80)
Available: Now

DEPARTMENT DÉCOR*

PAINT REINVENTION

***Includes following décor items with the following offers:**

1. “Your Choice Of ONE Free Item”: Choose one of the following FREE offers:

(1) Retrofit Kit for Front Desk Order Part #100 (pages 12-22 of the Catalog).

- Alternative Offer: \$800 credit toward the cost of new Front Counter - Stainless Counters (4' + 3') Order Part #80

(2) Center Hospitality End-Cap FREESTANDING (Order Part #1100), Dress Up Kit for Existing End Cap (Order Part #1200)
OR Category Sign with/without soft pillar (Order Part #s 900 or #901)

2. Items with a FREE Offer — Department Overhead Sign Order Part #1800 (required component)

3. Items with Special Credit Offer (window signage – optional component)

4. Optional items For Purchase (eligible for datings, subject to a minimum balance due of \$1,000)

For any questions regarding your Order or items in this Catalog work with your DM or e-mail
ReinventDecorOrders@acehardware.com

NEW PAINT COUNTER

DEPARTMENT DECOR

1. 4' Retailer Work Station is a solidly constructed workspace with a stainless steel countertop. The 4' section is dedicated specifically for retailers to set their color matching computer, paint tools and any other materials necessary to service the customer. A heightened ledge conceals any mess. The counter also contains holes for cord management.
2. 3' ADA Consumer Counter is a perfect place for customers to approach. The height is specifically designed to meet ADA requirements. An additional 3' wing panel can be purchased for retailers who have extra space to balance the other side.
3. Brand Glorifier quickly focuses the customer to the primary paint brands carried in store. They feature key product information and a full-size (empty) gallon cans for brand connection. It's adjustable - meaning, cans and placards can be removed if retailers don't carry specific brands.
4. Tinted Pint Counter Display (not shown) includes all 120 "Simple.Smart.Beautiful" colors in a portable take-home piece that they can keep as a ready reference for future paint projects.



4. Image not available.

Page #4 of Order Form
New Paint Counter
Part #80 Offer: Optional For Purchase, with "Your Choice Of" option: \$800 credit in lieu of Retrofit Kit (Part #100)
Available: Now
Specifications: 47.5"L x 38.375"D x 45"H (4ft portion) plus 38 3/8"L x 23 7/8"D X 33 1/4"H (3 ft portion)

Note: A credit of \$800 can be applied toward new counter IN LIEU OF RETROFIT KIT

FREE-STANDING ENDCAP - OPTION DETAILS

DEPARTMENT DECOR



1. Free-standing Flat Wall allows retailers to better utilize previously unused space. The wall does not require an individual endcap fixture. It's also sturdy enough to support a 42" TV monitor for a more engaging media experience. In addition, the wall unit comes with an endcap header that can be changed over time. The standard header graphic is "Your-Inspiration. Our Know-How". An additional header graphic is available for purchase for stores with two center endcaps.
2. Snap-Fit Frame Graphic sports promotional messaging and is meant to change out as needed. This frame is the same size as the standard endcap signage.

YOUR CHOICE OF ONE FREE ITEM

You can get this item for free
OR
the Category Sign and Soft Pillars
OR
the Center Gondola Dress-Up Kit

Page #1 of Order Form
Center Endcap
FREESTANDING WALL (only)
Part #1100
Offer: Your Choice of 1 FREE item
Available: Now

FREE-STANDING ENDCAP - OPTION DETAILS

DEPARTMENT DECOR



1. Free-standing Flat Wall allows retailers to better utilize previously unused space. The wall does not require an individual endcap fixture. It's also sturdy enough to support a 42" TV monitor for a more engaging media experience. In addition, the wall unit comes with an endcap header that can be changed over time. The standard header graphic is "Your-Inspiration. Our Know-How". An additional header graphic is available for purchase for stores with two center endcaps.
2. Snap-Fit Frame Graphic sports promotional messaging and is meant to change out as needed. This frame is the same size as the standard endcap signage.
3. Mini Tinted Pint Shadow Box (option) showcases both the Clark+Kensington and Valspar tinted pints and encourages consumers to take the guess-work out of color selection.
4. Table (option) attaches to the Free-standing wall and promotes a comfortable space for consumers to relax and evaluate color options.
5. Chair (option) displays inspirational photography in an engaging rotational video that sparks imaginations and gets consumers excited to transform their space.
6. 42" Monitor (option) is perfect for retailers that want to provide a more stimulating atmosphere for customers. Content of the monitors will be refreshed periodically

Page #1 of Order Form
 Center Endcap
 Free-Standing Wall with Endcap Header
 and Snap Fit Graphic
 Part #1100
 Offer: Your Choice of 1 FREE Item
 Available: Now

Page #1 of Order Form
 Mini Tinted Pint Shadow Box
 Part #1510
 Offer: Optional For Purchase
 Available: Now

Page #1 of Order Form
 Hospitality Table and Chairs
 Table (Part #1300)
 Chairs (Part #1400)
 Offer: Optional For Purchase
 Available: Now

Page #3 of Order Form
 42" Media Player
 Part #1600
 Page # Info
 Offer: Optional for Purchase
 Available: Now

FREE-STANDING ENDCAP - PINT SHADOW BOX DEPARTMENT DECOR



1. Free-standing Flat Wall allows retailers to better utilize previously unused space. The wall does not require an individual endcap fixture. It's also sturdy enough to support a 42" TV monitor for a more engaging media experience. In addition, the wall unit comes with an endcap header that can be changed over time. The standard header graphic is "Your-Inspiration. Our Know-How". An additional header graphic is available for purchase for stores with two center endcaps.
2. Snap-Fit Frame Graphic sports promotional messaging and is meant to change out as needed. This frame is the same size as the standard endcap signage.
3. Large Tinted Pint Shadow Box (option) showcases both the Clark+Kensington and Valspar tinted pints and encourages consumers to take the guess-work out of color selection. There are shelves at the bottom that allow retailers to stock actual product for quick and convenient product accessibility.
4. 42" Monitor (option) is perfect for retailers that want to provide a more stimulating atmosphere for customers. Content of the monitors will be refreshed periodically.

Page #1 of Order Form
Center Endcap
FREESTANDING WALL (only)
Part #1100
Offer: Your Choice of 1 FREE Item
Available: Now

Page #3 of Order Form
Large (Full Set) Tinted Pint
Shadow Boxes and Shelves
Part #1500
Offer: Optional for Purchase
Available: Now

CENTER ENDCAP DRESS-UP KIT

DEPARTMENT DECOR



This Kit is to dress up an existing 36" in-store endcap unit.

1. Dress Up Kit allows retailers to better utilize previously unused space. This kit dresses up an existing endcap fixture (i.e. Lozier or Madix or other) that the store already has in the dept. Retailers can use this space to planogram key sundries, "staff picks", or other project essentials. A planogram of key project essentials is available on ACENET. In addition, the wall unit comes with an endcap header that can be changed over time. The standard header graphic is "Your-Inspiration. Our Know-How". However, for this endcap, we recommend the "Project Essentials" sign for the Snap-Fit Graphic. Finally, side pillars come with the kit to finish the look of the display. Special Note: the Dress-Up Kit will NOT support a TV Monitor.
2. Snap-Fit Frame Graphic sports promotional messaging and is meant to change out as needed. This frame is the same size as the standard endcap signage.

Page #1 of Order Form
Dress-Up Kit for Existing In-Store Fixture
Part #1200 Offer: Your Choice of 1 FREE Item
with this item or Part # 1100 Center Hospitality End Cap -
FREESTANDING. Or Part #900-901 Category Sign and Soft Pillars.
Available: November 1, 2013
Specifications: 41"L x 3"D x 113"H (with Header)

OVERHEAD SIGNAGE

DEPARTMENT DÉCOR

1. The Paint Studio Overhead Sign is designed to brand the paint department, anchor the space of the main paint valley and convey inspirational color messaging.
2. Three (3) frosted acrylic panels on front and back hold a channel for the main sign. The graphic is designed to change out over time to keep the department message fresh and exciting.
3. Brand signage is showcased on the side panels to underscore the two main paint brands: Clark+Kensington and Valspar.
4. A bracket (not shown) is available to convert to a wall-mount for low ceiling stores.



4. Image not available.

Page #3 of Order Form
Department Overhead Signage
Part #1800 Offer: FREE
Available: Now
Specifications: 80.82"L x 40.03"D x 23.875"H

CATEGORY SIGNAGE

DEPARTMENT DÉCOR



1. **Way-finding Messaging** – These signs provide superior way-finding messaging to help get customers to their selection fast. The double-sided messaging marks off key Sundry categories in the Paint Valley.
2. **Flexible scrim material** features fun messaging and allows for easy maneuvering in tight aisles and does not encroach on ADA aisle standards.
3. **Lighting (option)** – It’s easy to create a big impact and exceptional way-finding with this energy efficient, innovative accent lighting. The LED light strip gives off light with a single-color for a strong visual appeal. Cord measures 1.5” long. s available to convert to a wall-mount for low ceiling stores.

Page #3 of Order Form
 Category Signs (full set , includes Scrim)
 Parts #900-901 Offer: Your choice of 1 FREE Item with this item or Part # 1100 Center Hospitality End Cap - FREESTANDING. Or Part #1200 Center Hospitality End Cap - RETROFIT.
 Available: Now
 Specifications: 18”L x 1.5”D x 92.5”H (scrim and sign)

Page #3 of Order Form
 Category Sign (without Scrim)
 Part #901 Offer: Your choice of 1 FREE Item with this item or Part # 1100 Center Hospitality End Cap - FREESTANDING. Or Part #1200 Center Hospitality End Cap - RETROFIT.
 Available: Now
 Specifications: 18”L x 1.5”D x 12”H (each sign)

Page #3 of Order Form
 Category Marker Lighting
 Part #1000 Offer: Optional for Purchase
 Available: Now
 Specifications: 28” Long Strip Light with Power Source.

EQUIPMENT SHROUD

DEPARTMENT DÉCOR



1. **Expandable Wall** - The equipment shroud is designed to conceal clutter and unsightly machinery in the work hub. The standard equipment shroud comes equipped with a full 6' wall (plus supportive pillars) and two side walls each 2' wide. Additional extensions are available to expand the shroud as needed.
2. **Literature Holders** - The literature holder is adjustable to accommodate non-core color collateral such as Exterior Stains, Rust Preventatives, Faux Finishing products and more.
3. **Open Back** - The back remains open for retailers to merchandise shippers or other low-profile products at their discretion.
4. **Expandable Panels (option)** - These extensions are perfect for retailers who need to conceal more pieces of equipment in their work hub. Available in 2' and 4' sizes.

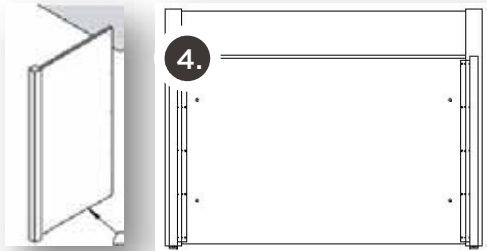

Expandable Panels

Page #4 of Order Form
 Equipment Shroud
 Parts #1700 Offer: Optional For Purchase
 Available: Now
 Specifications: 81.321"W x 30.335"D x 50.75"H

Page #4 of Order Form
 Equipment Shroud Expandable Panels
 Parts #1701-1702 Offer: Optional For Purchase
 Available: Now
 Specifications: 24" or 48"W x 50.75"H

PAINT MIXING WORK STATION

DEPARTMENT DECOR



- 1. Stainless Steel Top -** The paint mixing work station is designed to handle the tough job of hammering down the paint lid after mixing. Made a durable stainless steel, this station will last for years to come.
- 2. Shelf -** The work station comes equipped with a built-in shelf unit for quick-reach to stored items such as paint stirrers, can openers, hair dryers, rags, etc.
- 3. Open Space for 1G Shaker -** This open space is designed to house a standard 1-Gallon Shaker. The space-saving design is perfect for cramped working quarters and utilizes precious floor space efficiently.

Page #4 of Order Form
Rear Counter Paint Mixing Work Station
Part #2000 Offer: Optional For Purchase
Available: Now
Specifications: 20"L x 26"D x 38"H

DÉCOR WINDOW SIGNS

*Page #3 of Order Form, Parts #1910-1950
Fluoresco Interior Window Panel Replacements
Special Offer: Up to \$200 Credit any one sign
Available: Now
Specifications:

- Part #1910: Decorated replacement face only (4 sizes) -
(1) 1'6" x 3'; (2) 3' x 3' or (3) 3' x 6' or (4) 3' x 12'
- Part #1920: Single sided interior window sign - (1) 1'6" x 3' or (2) 3' x 3'
- Part #1930: Double sided interior window sign - (1) 1'6" x 3' or (2) 3' x 3'
- Part #1940: Single sided exterior wall mount sign - (1) 3' x 6' or (2) 3' x 12'
- Part #1950: Single sided co-brand wall mount sign 3' x 12'



Page #3 of Order Form
Exterior Dual-Branded Sign (3' x 6')
Part # 1910 (replacement face only)
Part # 1940 (complete sign)
Special Offer: Up to \$200 Credit any one sign
Available: Now
Specifications: 3'H x 6'W

THE PAINT STUDIO 

DREAM IN COLOR

EQUIPMENT & INSTALL CATALOG

PAINT REINVENTION EQUIPMENT & INSTALL CATALOG



PRODUCT CATALOG

TABLE OF CONTENTS

TODAY



REINVENTED



LET'S GET STARTED!

PRODUCT CATALOG

TABLE OF CONTENTS

SUMMARY OF KEY TERMS 5

EQUIPMENT AND SOFTWARE 6

SUMMARY OF KEY TERMS AND CONDITIONS

ACE + VALSPAR FULL PROGRAM PARTICIPATION

1. 100% credit – for the following components including unit cost, install and applicable other expenses

- Color Centers: Ace recommended configuration of 8' Chip Racks (or in limited cases 4' Chip Rack) for Ace and Valspar AND 3' End Caps for Ace and Valspar
 - Any 4' chip rack recommendation is eligible for an upgrade to an 8' chip rack for a full credit
 - Retailer is not eligible to downgrade from an 8' to a 4' chip rack
- Department Overhead Sign
- Ace recommended Tinter configuration
- Reset labor – up to twenty 4' section merchandise moves WITHIN PAINT DEPARTMENT. Retailer WILL BE RESPONSIBLE for the cost of any merchandise moves above this limit
- Installation for the listed components, freight, delivery to Retailer door, shipping, handling and taxes for these components.

2. Funded Décor – “Your Choice Of One Free Item”:

- (1) Paint Counter Retrofit for one complete counter which may include front counter and backdoors.
 - Alternatively, Retailer may elect to apply a credit of \$800 for New Stainless Desk.
- (2) “Your Choice of ONE Free Item”: one Center Hospitality End-Cap OR one Set of Category Markers with or without Soft Pillar (set of 6 markers)
 - Center Hospitality End-Cap offer includes either (1) a new FREESTANDING fixture OR (2) a DRESS-UP kit for the existing 3' End Cap (Dress-Up Kit requires an existing fixture)
 - Freestanding Center Hospitality End-Cap does NOT include any additional hospitality area components.

3. Window/Exterior Signs

- Any window sign upgrade will receive a \$200 credit. Includes window face replacements, interior or exterior signs.
- Alternatively - orders placed outside of this ordering process, including orders placed with Retailer's local vendors, may be eligible for coop funds. Note: the mechanics of the coop credit process are in development. Please request further details at ReinventDecorOrders@acehardware.com

4. Other Optional and Mandatory Components – for Purchase

- Décor, tinting equipment and peripherals – upgrades available with cost difference funded by Retailer
- Color matching software and equipment – all upgrades funded by Retailer. Ace/Valspar Formula Book upgrade FUNDED BY ACE.
- Reset labor and fixturing – any cost above twenty 4' section merchandise moves or additional fixturing work outside of Ace funded components

5. Credit Terms: Any net balance due from Retailer is eligible for 180-days datings terms, subject to a minimum balance due of \$1,000.

6. Any Retailer NOT participating in the Valspar Program will represent an exception and must be routed to ReinventDecorOrders@acehardware.com for approval; If approved - Only 50% credit will be eligible.

EQUIPMENT

PAINT REINVENTION

NOTE: Your Order Form will only reflect models for your existing vendor(s) today. If your Order Form does NOT reflect any of the vendors in this catalog or you are interested in additional options - please follow up with your DM for further instructions. Note: we are only able to offer PROGRAM EXCLUSIVE terms for vendors presented in this catalog. In addition, we may not be able to provide operational and credit support on any options outside of the scope of this catalog.

***Order Form pages 5-6 as applicable. See Order Form for pricing, terms and conditions**

For any questions regarding your Order or items in this Catalog work with your DM or e-mail
ReinventDecorOrders@acehardware.com

TINTERS AND RELATED COMPONENTS EQUIPMENT

1. We have partnered with FLUID MANAGEMENT as our preferred vendor for tinting equipment and related peripheral components. Fluid Management is an international industry leader and, as part of this Program, has offered Ace Retailers state of the art equipment and technology at Ace EXCLUSIVE prices and terms - within the scope of this Program.
2. For Retailers who currently operate non-Fluid Management systems - we have partnered with two industry leaders COROB/CPS and HERO - and we are able offer a full selection of each vendor's current systems and equipments at Ace EXCLUSIVE prices and terms within the scope of this Program.
3. Retailer Order Form will reflect Retailer recommendation for the appropriate system based on vendor recommendations and Ace expected store growth volume.
4. Note: Tinters in your Purchase Order include a full credit for an Ace recommended model configuration. You may choose another tinter model presented and apply a credit up to the amount of the Ace recommended unit.
5. Other tinting equipment (shakers, mixers) are available For Purchase.
6. SERVICE PLANS - to ensure proper operation, technical support and maximize quality useful life of your equipment - we have negotiated EXCLUSIVE terms and conditions with each vendor to offer Ace Retailers an Exclusive Service Maintenance and (for some vendors) Extended Warranty plans. See details in each vendor's section. (Note: these plans are in addition to standard manufacturers' initial part/labor warranty for new models, as applicable).
7. For any further questions - please work with your DM to address or email us at ReinventDecorOrders@acehardware.com

ACE PREFERRED VENDOR: FLUID MGMT EQUIPMENT

1. **NOTE:** Your order form will only reflect models for your vendor(s) today. Our recommendation is based on vendor record and store-specific volume growth projection. If the recommendation provided in your Order Form needs to be updated or you have any questions — please email ReinventDecorOrders@acehardware.com
2. Fluid-Only go-forward units include 16-canister AT1500 and higher models. All other models will be recommended to be replaced with a new unit as part of this Program. Please refer to your Order Form to confirm your recommendation.
3. If your order form does NOT reflect any of the vendors in this catalog or you are interested in additional options, please follow up with your DM for further instructions. Note: we are only able to offer PROGRAM EXCLUSIVE terms for vendors presented in this catalog. In addition we may not be able to provide operational and credit support on any options outside of the scope of this catalog.



EQUIPMENT SUMMARY COMPARISON

EQUIPMENT

	X-SMART Economic	AT1500 Versatile	AT7000 HS* Destination	AT8000 ELITE SUPER
SPEED PER PUMP/MACHINE	6 Ounce/Minute	7.5 Ounce/Minute	16.5 Ounce/Minute	30 Ounce/Minute
SEQUENTIAL/SIMULTANIOUS	Sequential	2-Color Simultaneous	4-Color Simultaneous	5-Color Simultaneous
1 OUNCE DISPENSE	10 Seconds	8 Seconds	3.75 Seconds	2 Seconds
4 OUNCE DISPENSE	40 Seconds	32 Seconds	14.5 Seconds	8 Seconds
8 OUNCE DISPENSE	1 Minute 14 Seconds	1 Minute 4 Seconds	29 Seconds	16 Seconds
Max Dispense Fl. Oz. per Min	6	15	66	150

Notes:

1. Speed times do not take into account time for turnable indexing or opening of automatic nozzle closer.
2. AT7000HS* is standard speed pump, (4) position in AT7000 have high speed pumps that dispense at 25 ounces per minute.
3. Speeds are based on dispensing one color out of one canister and not the simultaneous dispense of multiple colors.

FLUID MANAGEMENT AUTO-TINTERS EQUIPMENT

QUICK FACTS

- DESIGNED WITH FLUID MANAGEMENT'S UNIQUE PISTON PUMP DESIGN
- SEQUENTIAL DISPENSER WITH EXCEPTIONAL ACCURACY
- CONSISTANT ACCURATE RESULTS REGARDLESS OF OPERATOR
- EASY MAINTENANCE AND SELF REPAIR
- **BEST SUITED FOR LOWER VOLUME STORES TINTING ONE GALLONS AND QUART CANISTERS**
- OPERATES WITH FLUID MANAGEMENT'S COLOR PRO SOFTWARE

Page #6 of Order Form
X-Smart Auto Tinter
Part #20.0
Offer: FREE with Recommendation
Available: Now

X-SMART The Economic Automatic Tinting Solution



PRODUCT DETAILS	Sequential Automatic Dispenser, 16-canisters, indexing turntable with piston pump technology
DISPENSE SPEED	6 to 8 ounces per minute (colorant dependent). Maximum total 8 ounces per minute
DIMENSIONS	33"W x 33"D x 47"H
CANISTER SIZE	(16) 2.25- quart canisters
PERIPHERALS INCLUDED	<ul style="list-style-type: none"> • PC and Monitor • ColorPro 4 Professional Software • Bar Code Scan Gun • Label Printer • Power Strip • Interface cable for two PC set up • Canister Wrap

FLUID MANAGEMENT AUTO-TINTERS EQUIPMENT

QUICK FACTS

- USES FLUID MANAGEMENT'S PATENTED DVX PUMP TECHNOLOGY
- 2-COLOR SIMULTANIOUS DISPENSING FOR FASTER THROUGHPUT
- UP TO 15 OZ COLORANT DISPENSE PER MINUTE
- EXCEPTIONAL ACCURACY AND RELIABILITY
- LOW DAILY MAINTENANCE
- **BEST SUITED FOR MID RANGE GROWTH RETAILERS SERVING THE DIY CUSTOMER TINTING ONE GALLON, QUART, AND OCCASIONAL FIVE GALLON PAILS (up to 10k gallons per year)**
- OPERATES WITH FLUID MANAGEMENT'S COLORPRO SOFTWARE

Page #6 of Order Form
AT-1500 Auto Tinter
Part #20.1
Offer: FREE with Recommendation
Available: Now

AT1500
The Most Versatile Automatic
Dispensing Solution for Ace Retailers



PRODUCT DETAILS	2-color Simultaneous Automatic Dispenser, 16-canisters with DVX pumping technology
DISPENSE SPEED	7.5 ounces per channel per minute with maximum 15 total ounces per minute
DIMENSIONS	36"W x 24"D X 48"H
CANISTER SIZE	(16) 3-quart canisters
PERIPHERALS INCLUDED	<ul style="list-style-type: none"> • PC and Monitor • ColorPro 4 Professional Software • Bar Code Scan Gun • Label Printer • Power Strip • Interface cable for two PC set up

FLUID MANAGEMENT AUTO-TINTERS EQUIPMENT

QUICK FACTS

- USES FLUID MANAGEMENT'S PATENTED DVX PUMP TECHNOLOGY
- 4-COLOR SIMULTANIOUS DISPENSING
- UP TO 100 OZ COLORANT DISPENSE PER MINUTE
- EXCEPTIONAL ACCURACY AND RELIABILITY
- LOW DAILY MAINTENANCE
- **DESIGNED FOR THE 'PAINT DESTINATION' SERVING ALL LEVELS OF THE MARKET INCLUDING COMMERCIAL CUSTOMERS (15k+ gallons per year)**
- OPERATES WITH FLUID MANAGEMENT'S COLORPRO SOFTWARE

Page #6 of Order Form
AT7000 HS Auto Tinter
Part #20.2
Offer: FREE with Recommendation
Available: Now

AT7000 HS

The Automatic Dispensing Solution
for the 'PAINT DESTINATION' Retailer



PRODUCT DETAILS	4-color Simultaneous Automatic Dispenser, 16-canisters with DVX pumping technology
DISPENSE SPEED	25 ounces per channel per minute on the 4 highest usage colorants, 16.5 ounces per minute on all others with maximum total of 100 ounces per minute
DIMENSIONS	45"W x 30"D x 45"H
CANISTER SIZE	(8) 6-quart, (8) 4-quart canisters
PERIPHERALS INCLUDED	<ul style="list-style-type: none"> • PC and Monitor • ColorPro 4 Professional Software • Bar Code Scan Gun • Label Printer • Power Strip • Interface cable for two PC set up

FLUID MANAGEMENT AUTO-TINTERS EQUIPMENT

QUICK FACTS

- USES FLUID MANAGEMENT'S PATENTED DVX PUMP TECHNOLOGY
- 5 COLOR SIMULTANIOUS DISPENSING
- UP TO 150 OZ COLORANT DISPENSE PER MINUTE
- EXCEPTIONAL ACCURACY AND RELIABILITY
- LOW DAILY MAINTENANCE
- **DESIGNED FOR HIGHEST VOLUME LOCATIONS INCLUDING MULTIPLE GALLONS AND 5-GALLON ORDERS, CONTRACTOR/COMMERCIAL VOLUMES**
- **OPERATES WITH FLUID MANAGEMENT'S COLORPRO SOFTWARE**

Page #6 of Order Form
 AT8000 Elite Auto Tinter
 Part #20.3
 Offer: FREE with Recommendation
 Available: Now

AT8000 Elite

The Automatic Dispensing Solution
 for the 'PAINT DESTINATION' Retailer



PRODUCT DETAILS	5-color Simultaneous Automatic Dispenser, 16-canisters with DVX pumping technology
DISPENSE SPEED	30 ounces per channel per minute with maximum total of 150 ounces per minute
DIMENSIONS	45"W x 43"D x 45"H
CANISTER SIZE	(4) 5-gallon, (12) 6-quart canisters
PERIPHERALS INCLUDED	<ul style="list-style-type: none"> • Roller Conveyor for 5-gallon pails • PC and Monitor • ColorPro 4 Professional Software • Bar Code Scan Gun • Label Printer • Power Strip • Interface cable for two PC set up

FLUID MANAGEMENT MIXERS & SHAKERS EQUIPMENT



**Fluid Management
5G-HD Heavy
Duty Shaker**

Versatile mixing solution for your paint department

FEATURES INCLUDE:

- Capable of mixing (1) 5-gallon pail, up to (4) 1-gallon cans, up to (6) quart cans
- 3 minute mechanical timer
- 80 lbs. load capacity
- 28" wide x 28" deep x 45.5" High
- 2 year part, 1 year labor warranty

Page #6 of Order Form
5G-HD Heavy Duty Shaker
Part #50000
Offer: Optional for Purchase
Available: Now



**Fluid Management
VR-1 Vortex
Mixer**

Durable mixing solution for 1-gallon and quart containers

FEATURES INCLUDE:

- Three preset digital timer buttons for light, medium, and dark colors
- Quart adapter included
- 14 lbs. load capacity
- 17" wide x 24" deep x 28" High
- 2 year part, 1 year labor warranty

Page #6 of Order Form
VR-1 Vortex Mixer
Part #51000
Offer: Optional for Purchase
Available: Now

FLUID MANAGEMENT SERVICE PLAN*

EQUIPMENT

Extended Warranty and Service Plan (AT1500 models and above, including new units and retrofits):

1. As part of Paint Reinvent Program, Fluid Management has offered an Exclusive Extended Warranty and Service Plan to Ace Retailers at Exclusive Program prices. This Plan is designed to provide a priority resolution of any Retailers concerns when operating Fluid equipment, preventive maintenance for systematic equipment monitoring and 48-hour restore guarantee. This special plan is recommended for all eligible models and is designed to extend quality useful life of Fluid's equipment.

2. Specific terms and conditions:

- Fluid Management will provide a Service Level Agreement (SLA) that will guarantee a 36 hour response /48 hour restore 85% of the time. All states coverage guarantee except AK, HI and PR. Best efforts commitment of the same terms for AK, HI and PR.
- 36 hour on-site response (see comments regarding AK and HI).
 - For AT1500, AT2000, AT7000 and AT8000 RESPONSE time is based on having a technician on site at a retailer's location after it has been determined that an onsite visit by a technician is required in order to restore the machine to operating condition. All other options will be exhausted before a technician is dispatched.
 - For X-Smarts RESPONSE time is based on parts covered under warranty arriving within 36 hours at the retailers location (excludes Sundays and Holidays). Part requirement must be identified before 12:00 PM for next day delivery.
- The Extended Warranty begins in month 25 of service.
- Mirroring the OEM warranty including PC but not peripherals
 - Peripherals include label printer, barcode scanner, mouse and keyboard
- Preventative Maintenance includes:
 - Scale calibration of colorants
 - Software updates
 - Full revision of machine performance
 - Additional operator training as needed
- FMDirect Connect™ Remote Diagnostics and Troubleshooting
- Dedicated 1-800 phone line/priority phone queue access for Ace Retailers
- Priority on-site support

Page #6 of Order Form
Fluid Mgmt Service Plan
Offer: Optional for Purchase
Available: Now

Service Plan Terms

- 1. To take advantage of this special offer, Retailer needs to agree to participate in this Program for the 3-year period, during Reset and after the installation or conversion of an existing unit has been completed.**
- 2. Program billed at time of machine purchase. Due in 3-year installments of years 3, 4 and 5 of services.**

COROB/CPS TINTERS AND RELATED COMPONENTS EQUIPMENT

- **NOTE:** Your order form will only reflect models for your vendor(s) today. Our recommendation is based on vendor record and store-specific volume growth projection. If the recommendation provided in your Order Form needs to be updated or you have any questions – please email ReinventDecorOrders@acehardware.com
- For Corob/CPS units – the only existing go forward model is D300. All other models will be recommended to be replaced with a new unit as part of this Program. Please refer to your Order Form to confirm your recommendation.
- If your order form does NOT reflect any of the vendors in this catalog or you are interested in additional options – please follow up with your DM for further instructions. Note: we are only able to offer PROGRAM EXCLUSIVE terms for vendors presented in this catalog. In addition we may not be able to provide operational and credit support on any options outside of the scope of this catalog.

EQUIPMENT SUMMARY COMPARISON

EQUIPMENT

UNIT TYPE	TARGET STORE	DISPENSER PRECISION	DISPENSER SPEED	VOLUME OF COLORANTS PER CIRCUIT PER MIN	TOTAL DISPENSER SPEED
D200 SIMO	Versatile	1/384 oz.	4 circuits at time picked 4	7 ounces	28 oz. per min.
FIRST 70	Destination	1/384 oz.	Any 4 circuits at a time	7 ounces	28 oz. per min.
D600	Super	1/384 oz.	4 circuits at time any 4	17 ounces	136 oz. per min.

COROB/CPS AUTO-TINTERS EQUIPMENT



D200

PRODUCT DETAILS

- Precision, affordability and reliability
- Fully-Automatic Sequential or Simultaneous
- Compact with 1/384 ounce dispense
- 16x 2.5 quart canisters
- Serious alternative to a manual dispenser
- Low maintenance
- Patented Bellows pump technology
- Available as Floor-Standing or Countertop mode

Page #6 of Order Form*

D200

Offer: Optional for Purchase

Available: Now

* Reflected in the Order Form for existing Corob Retailers

COROB/CPS AUTO-TINTERS EQUIPMENT



FIRST 70

PRODUCT DETAILS

- Compact, Simultaneous
- Fully-Automatic Simultaneous Bellows technology- up to 4 Canisters dispensing 28 ounces of colorant at one time
- Small Footprint accurately tints Sample, Quart, Gallon & 5-gallon containers
- Low maintenance matched to a sturdy metal frame
- Ergonomically designed for quick and easy operation, from the clear operator interface to effortless dispensing
- Compact frame size to optimize retail space

Page #6 of Order Form*

First 70

Offer: Optional for Purchase

Available: Now

* Reflected in the Order Form for existing Corob Retailers

COROB/CPS AUTO-TINTERS EQUIPMENT

D600



PRODUCT DETAILS

- 1/384 oz. dispense
- High Efficiency in a mid-size machine
- 5-gallon roll conveyor with 1-gallon lift up shelf
- 16 x 1.5 gallon canisters
- Standard or High Flow pumps
- Humidification system option to prevent tip drying
- Automated capping system

Page #6 of Order Form*

D600

Offer: Optional for Purchase

Available: Now

* Reflected in the Order Form for existing Corob Retailers

COROB/CPS SERVICE PLAN*

EQUIPMENT

Service Plan:

- 24/7 dedicated call-in service line.
- Direct toll free number for Ace Retailers: 888-277-9909. All service calls will go directly into CPS Technical service team bypassing all prompts.
- Remote diagnostics and formula remote downloading available with COROB InnovaTint software.
- With the launch of the new low VOC colorant, daily maintenance will be a must. CPS will create a customized training video for Ace (in English and Spanish) for daily maintenance tasks.

Annual equipment checkup:

CPS Color will offer a contract service COLOR ASSURANCE in years 3, 4 & 5 of the life of the FIRST1, D200, FIRST 70 automated tinters. Color Assurance must be purchased 60 days prior to the end of each warranty year.

- D600 and Tatocolor: Suggested at 18 months. Once per year following the 18 months.
- D300: This piston unit would not require an annual calibration. A calibration is only required when the unit shows signs of color drift.
- FIRST1, FIRST 70 and D200: These Bellows units would not require an annual calibration. A calibration is only required when the unit shows signs of color drift.
- Additional charges apply for travel and break fix

COLOR ASSURANCE TERMS AND CONDITIONS:

A COLOR ASSURANCE Service will be provided on the aforementioned equipment once per year in years 3, 4 & 5 from equipment rollout consisting of:

- One full visual evaluation of the dispensing unit
- Check calibration of all dispenser circuits, perform calibration if needed
- Inspection of dispenser for safe operation
- Inspection and adjustment of the nozzle cap, cleaning and lubrication
- Cleaning of nozzle tips
- Testing of all functions of the dispenser for proper operation
- Training of associates on the use and maintenance of the dispenser
- Confirming communication of the Color Computer to the COROB unit

Page #6 of Order Form
Corob/CPS Service Plan
Offer: Optional for Purchase
Available: Now

HERO TINTERS AND RELATED COMPONENTS EQUIPMENT

- **NOTE:** Your order form will only reflect models for your vendor(s) today. Our recommendation is based on vendor record and store specific volume growth projection. If the recommendation provided in your Order Form needs to be updated or you have any questions — please email ReinventDecorOrders@acehardware.com
- The following Hero auto-tinters are considered go-forward operating models and do not require a replacement: A200, A250, A450. Please refer to your Order Form to confirm your recommendation.
- If your order form does NOT reflect any of the vendors in this catalog or you are interested in additional options - please follow up with your DM for further instructions. Note: we are only able to offer PROGRAM EXCLUSIVE terms for vendors presented in this catalog. In addition we may not be able to provide operational and credit support on any options outside of the scope of this catalog.

HERO AUTO-TINTERS EQUIPMENT

ARCHIMEDE 200 SERIES

A210 Sequential (1) Colorant Dispense
A260 Sequential (4) Colorant Dispense



PRODUCT DETAILS

- **Flow Rate: up to 40 ounces per minute (up to 30 ounces per minutes for A210)**
- **Progressive Cavity Pump (PCP) Technology**
- **Average Precision +/- 1%**
- **Compatible with Water-based, VOC Free or Universal Colorants**
- **16 Canisters**
- **Canister Capacity: 2.6 quarts**
- **Automatic humidifier cap**
- **Laser cross hair can or bung hole locator**

Page #6 of Order Form*
Archimede 200 Series
Offer: Optional for Purchase
Available: Now

* Reflected in the Order Form for existing Hero Retailers

HERO AUTO-TINTERS EQUIPMENT

EUREKA 400 SERIES

A 450 Simultaneous (4) Colorant Dispense



PRODUCT DETAILS

- **Flow Rate: 40 ounces per minute**
- **Progressive Cavity Pump (PCP) Technology**
- **Average Precision +/- 1%**
- **Compatible with Water-based, VOC Free or Universal Colorants**
- **16 Canisters**
- **Canister Capacity: 16 circuit - 12 x 3.7 Quart + 4 x 5.1 Quart**
- **Automatic humidifier cap**
- **Laser cross hair can or bung hole locator**

Page #6 of Order Form*

Eureka 400 Series

Offer: Optional for Purchase Available: Now

* Reflected in the Order Form for existing Hero Retailers

HERO AUTO-TINTERS EQUIPMENT



S2450 Vortex mixer
(1-gallon vortex mixer)

Page #6 of Order Form
S2450 Vortex Mixer (1-gallon mixer)
Part #52000
Offer: Optional for Purchase
Available: Now



S2700 Case mixer
(5-gallons, 1-gallons, 4 -
1-gallon case, 7 - 1-quart cans)

Page #6 of Order Form
S2700 Case Mixer (5G Shaker -
handles gallons and quarts too)
Part #53000
Offer: Optional for Purchase
Available: Now



S2100 Line Vortex Mixers
(1-gallon, 5-gallon, 5-gallon heavy
duty, 5-gallon ergonomic)

Page #6 of Order Form
S2100 Line Vortex Mixers
(Heavy Duty 5G Shaker -
handles gallons and quarts too)
Part #54000-55000
Offer: Optional for Purchase
Available: Now

HERO SERVICE PLAN*

EQUIPMENT

Extended Warranty and Service Plan:

- Plan is offered for any new A210, A260 or A450 AUTO-TINTERS
- All 5 years offered a comprehensive full-coverage warranty including parts, labor, travel costs, toll-free dedicated customer support line (bilingual support available), 24-hour maximum downtime (excludes remote regions or travel related delays).
- Annual Preventative Visit (optional). Parts extra.

Service Plan Terms:

- Billings in years 3-5 in January, on an annual basis for the succeeding years' coverage.
- Note: If no on-site service calls are required in Year 4 then an applicable credit will be applied to the cost of Year 5 coverage.

Page #6 of Order Form
Hero Service Plan
Offer: Optional for Purchase
Available: Now

COLOR MATCHING SYSTEMS*

EQUIPMENT

- NOTE: Your order form will only reflect models for your vendor(s) today. If your order form does NOT reflect any of the vendors in this catalog or you are interested in additional options - please follow up with your DM for further instructions. Note: we are only able to offer PROGRAM EXCLUSIVE terms for vendors presented in this catalog. In addition we may not be able to provide operational and credit support on any options outside of the scope of this catalog.
- Collaborating with vendors, we have developed recommendations for Ace Retailers to ensure their color-matching configuration will allow them to operate successfully with the new formula database and updated color cards library and is consistent with vendor requirements for software/PC specifications.
 - Retailer individual Order Form will present a recommendation for mandatory or optional software/equipment upgrade.
 - Xrite mandatory upgrades are required for ColorDesigner versions V7.7 or below. Upgrade required for software and computer. Go-forward version: ColorDesignerPlus 1.0 or higher
 - Datacolor mandatory upgrades are required for Paintmaker. Go-forward version: Paint 1.2
- We have partnered with X-Rite (ACE Recommended Vendor) and Datacolor to provide required equipment and software options at ACE EXCLUSIVE prices and terms - within the scope of this Program.
 - Color-matching software and equipment upgrades are Retailer responsibility.
 - Retailers will be eligible for 180-days datings subject to a minimum balance due of \$1,000 or higher.

*Order Form pages 6 as applicable. See Order Form for pricing, terms and conditions

ACE PREFERRED VENDOR: X-RITE EQUIPMENT

- NOTE: Your order form will only reflect models for your vendor(s) today. If your order form does NOT reflect any of the vendors in this catalog or you are interested in additional options - please follow up with your DM for further instructions. Note: we are only able to offer PROGRAM EXCLUSIVE terms for vendors presented in this catalog. In addition we may not be able to provide operational and credit support on any options outside of the scope of this catalog.
- Offer Terms:
 - Ace will fund the cost of the mandatory upgrade to the new formula book.
 - All other color-matching equipment and software upgrades are funded by the Retailer.
 - Retailers will be eligible for 180-days datings on their net balance due, subject to a minimum balance due of \$1,000.



ACE PREFERRED VENDOR: X-RITE EQUIPMENT



Plus



iVue
Spectrophotometer-
New Technology

SYSTEM INCLUDES:

- iVue Spectrophotometer-New Technology
- ColorDesigner Plus 2.0 Software
- Dell PC and 19" Monitor with Gold Warranty
- Dymo LabelWriter Printer
- ACE Paint software
- Competitors' fan deck kits

Super Bundle: Software + Spectro
Offer: Optional for Purchase
Available: Now

SYSTEM FEATURES:

- **Non-Contact Measurement:** iVue is the only instrument in the industry that provides non-contact measurement. Since measurements are taken from a distance of 1½", the customer's sample never touches the instruments optic system.
- iVue can measure wet samples without having to clean the lenses afterwards. Having this distance between the sample and the lenses greatly reduces maintenance and services costs.
- **Color Resolution:** iVue measures at 10nm intervals in color space (31 points) and output at 31 points (vs competition at 14-16 points)
- **unique LED illumination of the iVue should last 20 years**
- **Unique automated gloss measurement**

COLOR MATCHING SYSTEMS: MATCHRITE EQUIPMENT

ORDER PART #	ORDER FORM PART DESCRIPTION*	CREDIT OFFER*	WHAT IS INCLUDED*	WHO WOULD CONSIDER
60000	ColorDesignerPlus	Retailer funded	Software upgrade to ColorDesigner Plus 2.0 from any version below 10.0 (versions V7.7 or below are no longer supported.) Includes competitors' fan deck kits	Existing X-Rite Retailer who only needs to upgrade to new version of software. Their PC, spectro and label printer are relatively new and function properly
60001	Color Matching PC Package	Retailer funded	Dell PC and 19" Monitor with Gold Warranty	Existing X-Rite Retailer with an older PC (3+ years old). Software version is up-to-date (either ColorDesigner 10.0 or higher or ColorDesignerPlus)
60002	ColorDesignerPlus + PC Upgrade Package	Retailer funded	ColorDesigner Plus 2.0 Software including competitors' fan deck kits; Dell PC and 19" Monitor with Gold Warranty	Existing X-Rite Retailer with an old software (version V7.7 and below) and older PC (3+ years old)
60003	Xrite Spectrophotometer	Retailer funded	VS205 iVue Spectrophotometer - BRAND NEW NON CONTACT measurement technology	Any existing X-Rite Retailer who wants to upgrade to the NEW TECHNOLOGY or simply needs a new spectro
60004	Xrite Super Bundle		ColorDesigner Plus 2.0 Software including competitors fan deck kits; Dell PC and 19" Monitor with Gold Warranty + iVue Spectrophotometer + Dymo LabelWriter Printer	Complete Changeover - upgrade for existing X-Rite Retailer, conversion from another brand or anyone brand new to color-matching
60006	Database upgrade	Ace Funded	DB Upgrade	Existing Datacolor Retailer with all systems up-to-date and only requiring upgrade to the new Formula Book

*Ace/Valspar Formula Book upgrades are funded by Ace/Valspar in all part #s

COLOR MATCHING SYSTEMS: DATACOLOR EQUIPMENT

- NOTE: Your order form will only reflect models for your vendor(s) today. If your order form does NOT reflect any of the vendors in this catalog or you are interested in additional options - please follow up with your DM for further instructions. Note: we are only able to offer PROGRAM EXCLUSIVE terms for vendors presented in this catalog. In addition we may not be able to provide operational and credit support on any options outside of the scope of this catalog.
- Offer Terms:
 - Ace will fund the cost of the mandatory upgrade to the new formula book.
 - All other color-matching equipment and software upgrades are funded by the Retailer.
 - Retailers will be eligible for 180-days datings on their net balance due, subject to a minimum balance due of \$1,000.

COLOR MATCHING SYSTEMS: MATCHRITE EQUIPMENT

ORDER PART #	ORDER FORM PART DESCRIPTION*	CREDIT OFFER*	WHAT IS INCLUDED*	WHO WOULD CONSIDER
70000	Datacolor 1.2	Retailer funded	Software upgrade from Paintmaker + Fan Deck update + C+K/Valspar update	Existing Datacolor Retailer who only need to upgrade to new version of software. Their PC, spectro and label printer are relatively new and function properly
70002	Datacolor 1.2 + PC Upgrade Package	Retailer funded	PC Dell Computer (preloaded and tested) + Paint 1.2 + Fan Deck + C+K/Valspar update	Existing Datacolor Retailer with an older PC (3+ years old) and old software version
70003	Datacolor Spectrophotometer + Software Paint 1.2	Retailer funded	Spectro + Paint 1.2 + 650 + Fan Decks + C+K/Valspar update	Existing Datacolor Retailer who needs to replace or upgrade their older spectro
70004	Datacolor Super Bundle	Retailer funded	Spectro + Paint 1.2 + 650 + Fan Decks + C+K/Valspar update + Dell Computer (preloaded and tested) + Label Printer	Complete Changeover - upgrade for existing Datacolor Retailer, conversion from another brand or anyone new to color-matching
70006	Database upgrade	Ace Funded	Upgrade to Ace/Valspar new Formula Book	Existing Datacolor Retailer with all systems up-to-date and only requiring upgrade to the new Formula Book

*Ace/Valspar Formula Book upgrades are funded by Ace/Valspar in all part #s

COLOR MATCHING SYSTEMS: DATACOLOR EQUIPMENT



Super Bundle: Software, PC + Spectro
Part # 70004
Offer: Optional for Purchase
Available: Now

SYSTEM INCLUDE:

- Datacolor DC110 Spherical Spectrophotometer with 1/4" sample port. Includes one year parts and labor warranty
- Datacolor Paint 1.2 Software Ace Color Matching
- Database 650+ Competitive Fan Decks
- Dell Optiplex Computer w/Flat Panel Monitor. Includes 3-year onsite warranty
- Dymo Label Printer- 2-year warranty System comes ready to Plug and Play
- Install tech support INCLUDED
- Data conversion from another system/vendor: WAIVED (normally \$200)



Upgrade Package: Software + PC
Part # 70002
Offer: Optional for Purchase
Available: Now

SYSTEM INCLUDE:

- Datacolor Paint 1.2 Software
- Ace Color Matching Database
- 650+ Competitive Fan Decks
- Dell Optiplex Computer w/Flat Panel Monitor. Includes 3-year onsite warranty System comes ready to Plug and Play
- Install tech support INCLUDED

LABOR

PAINT REINVENTION

*Order Form page 7. See Order Form for pricing, terms and conditions

For any questions regarding your Order or items in this Catalog work with your DM or e-mail
ReinventDecorOrders@acehardware.com

RESET AND FIXTURE LABOR

LABOR

- **As part of the Program, Retailers will have the opportunity to update the layout of their Paint Department – including repositioning of fixtures and fixture installation.**
- **We have partnered with 5 major national reset groups who offered ACE EXCLUSIVE prices, terms and conditions within the scope of this Program.**
- **NOTE: ALL PRICES, TERMS AND CONDITIONS ARE EXCLUSIVE TO PAINT DEPARTMENT AND PAINT REINVENT PROGRAM. Quotes for reset, install or fixturing in other store departments or for other projects available upon request.**
- **Retailer offer includes**
 1. Up to twenty 4' sections moves 100% funded by Ace – NOT transferrable to other departments
 - Retailer is responsible for section moves ABOVE 20.
 2. Labor to install fixtures covered by FREE offer or “Choice Of ONE Free Item” offer — FREE
 - Retailer responsible for install labor for items offered FOR PURCHASE
 2. At the time of completing the Order Form — Retailer may request or may be recommended additional reset or install or fixturing work be completed at their store. Any such additional labor components are Retailer responsibility.

RESET AND FIXTURE LABOR

LABOR

- 4' Merchandising Section Move within Paint Department - 4' Merchandising Section Move within Paint Department (Liquid Paint and Paint Sundries) UP TO 20 sections, FREE to Retailer. DOES NOT include cost of moving Fixture, cost of Fixtures, Wall-Blocking Installation or Seismic Anchoring (Quotes for Merchandising Section Moves in Other Departments Available Upon Request). Twenty 4' section moves allowance is NOT transferrable to other departments.
- Move, Level & Anchor of Existing 4' Fixture to Manufacturer's Specification - Move, Level & Anchor of EXISTING 4' Fixture to Manufacturer's Specification (Labor for fixture move only - DOES NOT include cost of Fixtures, Installation of Wall Blocking or Merchandising within fixture).
- Installation, Level & Anchor of NEW 4' Fixture to Manufacturer's Specification - Labor for fixture move only. DOES NOT include cost of Fixtures, Installation of Wall Blocking or Merchandising within fixture.
- Installation of Wall Blocking to perimeter of wall per 4' section to Fixture Manufacturer's Specifications - Labor for wall-blocking only. Retailer to provide materials. Does NOT include cost of moving fixture, cost of Fixtures, or Merchandising within fixture.
- Seismic Anchoring of 4' Fixture and Base Brackets as required and to Fixture Manufacturer's Specifications - Retailer is to provide all necessary Anchors and Brackets. DOES NOT include wall-blocking, cost of moving fixture, cost of Fixtures, or Merchandising within Fixture.